

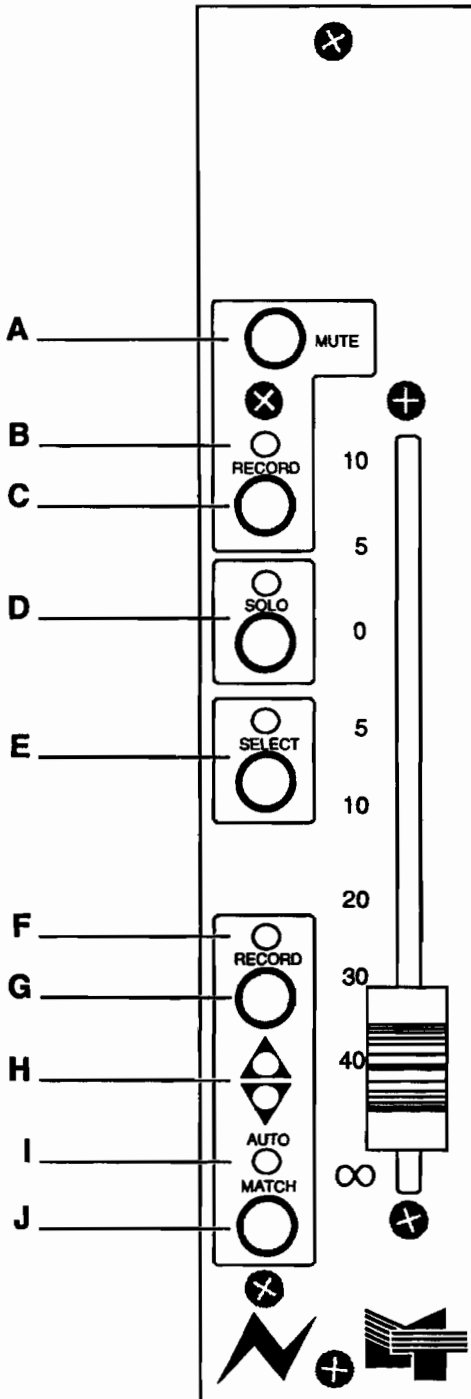

Fader, Mute, & Channel Button Modes

FADER, MUTE, & CHANNEL BUTTON MODES

FADER MODULE OVERVIEW



A. MUTE Button

This button is used to turn the mute on and off.

B. Mute RECORD LED

This LED is used as a recording indicator, RSI (Ready, Safe, and Isolate) indicator, and as a Touch Record and Lock Record indicator for the mute.

C. Mute RECORD Button

This button is used to toggle between mute Touch Record and Lock Record modes. When RSI on the Global Master is enabled, this button (used in conjunction with SELECT) is also used to toggle through RSI for the mute.

D. SOLO Button and LED

This button is used to place a channel in and out of Solo. The LED indicates that a channel is in Solo. (Solo must first be enabled at the Global Master.)

E. SELECT Button and LED

This button is used in conjunction with mute and fader RECORD for selection and interrogation of RSI, for the assignment and interrogation of Groups, Links and Solo banks, as a fader and mute touch indicator, and as a relay control button.

F. Fader RECORD LED

This LED is used as a recording indicator, RSI indicator, and a Touch Record and Lock Record indicator for the fader.

G. Fader RECORD Button

This button is used to toggle between Touch Record and Lock Record modes for the fader. When RSI on the Global Master is enabled, this button (used in conjunction with SELECT) is also used to toggle through fader RSI.

H. MATCH LEDs

The Match LEDs show the direction needed to move the fader in order to return it to the Play Pass position. They are also used for Group and Link interrogation.

I. AUTO/MATCH LED

This LED is used as a Match and Auto Match mode indicator.

J. MATCH Button

When pressed, a Match is performed. When used in conjunction with the fader RECORD button, the Auto Match mode will be activated.

GLOBAL MASTER MODULE OVERVIEW

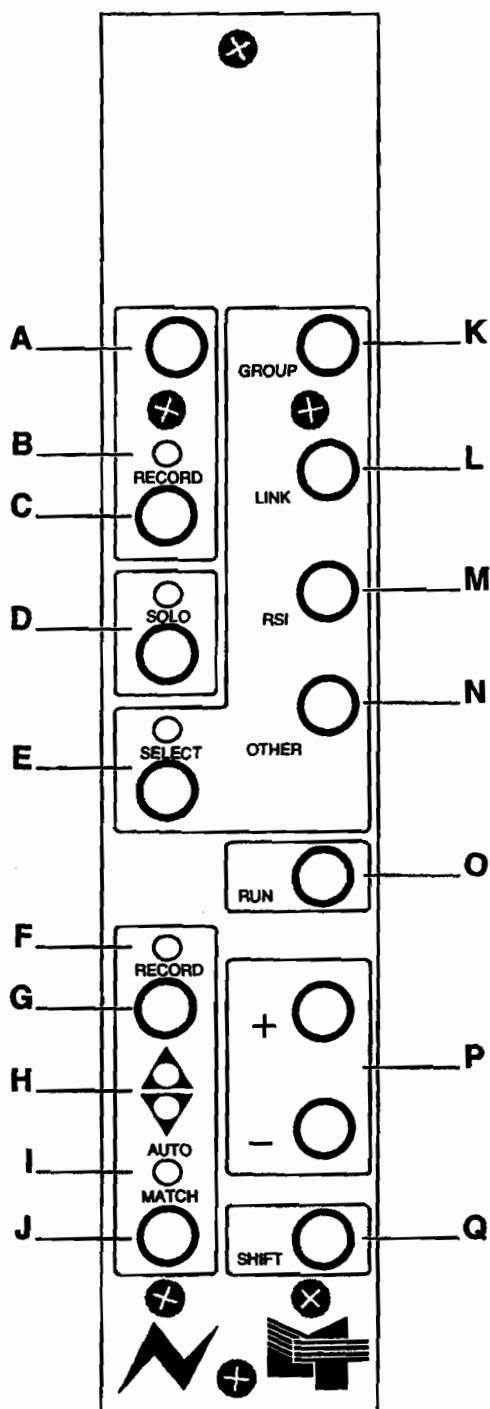

A. Master Touch Button and LED

Turns Master Touch on and off and indicates Master Touch status.

B. Mute RECORD LED

This LED is used as a global mute Touch Record and Lock Record indicator and a global RSI indicator.

C. Mute RECORD Button

This button is used to globally select mute Touch Record or Lock Record modes. When RSI is enabled, this button (used in conjunction with SELECT) is also used to globally toggle through mute RSI.

D. SOLO Button and LED

When used with the Global Master SHIFT, this button will enable and disable Solo. SOLO also selects between momentary and latching button operation, as well as serving as a global Solo cancel.

E. SELECT Button and LED

This button is used in conjunction with the mute or fader RECORD buttons for global RSI assignment and interrogation and for selection and interrogation of Groups and Links.

F. Fader RECORD LED

This LED is used as a global fader Touch Record and Lock Record indicator as well as a global fader RSI indicator.

G. Fader RECORD Button

This button is used to globally toggle between fader Touch Record or Lock Record modes. When RSI is enabled, this button (used in conjunction with SELECT) is also used to globally toggle between fader RSI.

H. MATCH LEDs

Inactive

I. AUTO/MATCH LED

This LED is used as a global Match and Auto Match indicator.

J. MATCH Button

When pressed, a Match is performed on a global level. When used in conjunction with the fader RECORD button, Auto Match will be activated for all faders.

K. GROUP Button

GROUP enables and disables the Group assign mode.

L. LINK Button

LINK enables and disables the Link assign mode.

M. RSI Button

RSI enables and disables the RSI select mode.

N. OTHER Button

OTHER currently enables and disables Trim or Graph, Set Solo Banks, Set Master Touch and Set Relay Control features.

O. RUN Button

RUN turns automation on and off.

P. Plus (+) and Minus (-) Buttons

The Plus (+) and Minus (-) buttons are used for incrementing and decrementing the Mix/Pass counter and for applying global Trim amounts.

Q. SHIFT Button

SHIFT is used in conjunction with the Plus (+) and Minus (-) buttons to change Mix numbers and for applying Global Trim amounts. It is also used as a modifier for the OTHER and SOLO buttons and for 'Locking' Master Touch on.

SELECT

The functions of the Select buttons are controlled by the GROUP, LINK, RSI, and OTHER buttons on the Global Master. The use of the Select button for each of the assign/select modes on the individual faders will be discussed in their instructions.

GROUP

This feature allows you to select a master fader and to assign slaves to that fader. If moves or mutes are made with the master, its slaves move or mute with it, but, moving or muting a slave does nothing to the master or to the other slaves. The master fader position does not provide an absolute level set to the slave faders, but rather a simple offset in level. This allows for a slave to completely override a group move (such as a fade) if desired. Mutes follow two simple rules:

1. If a group master is muted, all associated slaves will also be muted.
2. If a group master is unmuted, all associated slaves will reflect their individual status.

Important Channel buttons are not included in groups.

Group moves and mutes are recorded on the master fader only. This means that if a slave fader is removed from a group, it will no longer follow the fader moves or mute events associated with that group. Because of this, all group structures in a mix are included in the information which is kept to disk and groups are re-formed when the mix is loaded from disk. (See "Coalesce Groups" in Chapter 9.)

GROUP HIERARCHY

With Flying Fader groups, a multi-level group structure or hierarchy may be formed. A simple example would be to create four groups consisting of rhythm, strings, brass, and vocals respectively, then create another group with its slaves consisting of the master fader of the other four groups. In essence, what is being set up is a master, sub-master, slave arrangement.

SELECT

The functions of the Select buttons are controlled by the GROUP, LINK, RSI, and OTHER buttons on the Global Master. The use of the Select button for each of the assign/select modes on the individual faders will be discussed in their instructions.

GROUP

This feature allows you to select a master fader and to assign slaves to that fader. If moves or mutes are made with the master, its slaves move or mute with it, but, moving or muting a slave does nothing to the master or to the other slaves. The master fader position does not provide an absolute level set to the slave faders, but rather a simple offset in level. This allows for a slave to completely override a group move (such as a fade) if desired. Mutes follow two simple rules:

1. If a group master is muted, all associated slaves will also be muted.
2. If a group master is unmuted, all associated slaves will reflect their individual status.

Important Channel buttons are not included in groups.

Group moves and mutes are recorded on the master fader only. This means that if a slave fader is removed from a group, it will no longer follow the fader moves or mute events associated with that group. Because of this, all group structures in a mix are included in the information which is kept to disk and groups are re-formed when the mix is loaded from disk. (See "Coalesce Groups" in Chapter 9.)

GROUP HIERARCHY

With Flying Fader groups, a multi-level group structure or hierarchy may be formed. A simple example would be to create four groups consisting of rhythm, strings, brass, and vocals respectively, then create another group with it's slaves consisting of the master fader of the other four groups. In essence, what is being set up is a master, sub-master, slave arrangement.

A more complicated example would be a film mixdown, where the dialog mixer, music mixer, and effects mixer each set up their portion of the console with a master, sub-master, slave arrangement. The dialog mixer may then create group masters on his console for the music and effects mixes, and then place a grand master over everything. This set-up would have five levels of grouping.

GROUP CHARACTERISTICS

1. Any number of groups may be formed.
2. A master may have any number of slaves.
3. Any fader may be a group master, even if that fader is a slave in another group.
4. A slave can have only one direct group master. A slave may have any number of indirect group masters as a result of group hierarchy.
5. Group moves and mutes are recorded on the group master fader only. Slave moves and mutes (other than those caused by the group) are recorded on the respective slave fader.
6. The underlying status of a slave's mute may be toggled while the slave is responding to a group mute.
7. A fader cannot be assigned to one group and its mute to another.
8. RSI settings of a group master do not affect its slaves, and vice-versa.
9. When a mix is kept to disk, group structures are included in the mix information.
10. Groups are always functional, regardless of fader modes, automation status, or presence of timecode (unless they are Coalesced or Suspended). Refer to Chapter 9, "Gangs", for more information.
11. Channel buttons are not included in groups.
12. Solo does not respect group assignments. (Soloing a master will not solo its slaves.)

TO CREATE A GROUP:

1. Press GROUP on the Global Master to enable the group assign mode (GROUP LED on).

2. Press the SELECT button on the fader that is to be the group master (the SELECT LED will flash).
3. Press the SELECT button on each fader that you wish to add (SELECT LED on) or remove (SELECT LED off) from this group. (If a fader's MATCH LEDs are on dim, that fader is already a slave in another group and may not be a member of this group.)
4. Press the SELECT button on the group master (SELECT LED off).
5. Repeat for other groups or press GROUP on the Global Master to disable the group assign mode (GROUP LED off).

Note If you wish to delete all groups currently in RAM, refer to Chapter 9, "Gangs".

GROUP INTERROGATION

The following section contains three methods of group interrogation.

INTERROGATION BY USING SELECT:

1. Turn off all assign mode buttons (GROUP, LINK, RSI, OTHER) on the Global Master.
2. Press the SELECT button on the fader of interest.
3. The MATCH LEDs on all faders will stop showing any match offsets and display one of the following:
 - a. Upper MATCH LED on solid: The fader is an indirect master of the selected fader.
 - b. Upper MATCH LED flashing: The fader is a direct master of the selected fader.
 - c. Lower MATCH LED flashing: The fader is a direct slave of the selected fader.
 - d. Lower MATCH LED on solid: The fader is an indirect slave of the selected fader.
 - e. Both MATCH LEDs on dim: The fader is a slave in another group and is not eligible to be a slave to the selected fader.
 - f. Both MATCH LEDs off: The fader is not a member of a group.

INTERROGATION BY TOUCH:

1. Turn off the assign mode buttons (GROUP, LINK, RSI, OTHER) on the Global Master.
2. Touch a group master fader (its SELECT LED will flash).
3. All direct and indirect slaves will turn on their SELECT LEDs.

INTERROGATION OF OVERALL GROUP STRUCTURES:

1. Press GROUP on the Global Master to enable the group assign mode (GROUP LED on).
2. Press the SELECT button on the Global Master.
3. The SELECT LEDs on all faders will display one of the following:
 - a. SELECT LED off: Fader is not part of a group.
 - b. SELECT LED flashing bright: Fader is a group master only.
 - c. SELECT LED flashing dim: Fader is a group master to one group and a slave in another group.
 - d. SELECT LED on: Fader is a slave only.

Important For information on Group Coalesce, refer to Chapter 9, "Coalesce Groups", in the Gangs menu.

This feature allows you to interconnect faders so that moves or mute events that occur on any member of a link will be cloned to the other link members. Touching the fader or pressing the mute of a link member is exactly the same as touching all of the other members of the link at the same time.

Important Channel buttons are not included in links.

Link moves and mute events are recorded to each link member. This means that if a fader is removed from a link, it will still play back all previously written fader moves and mutes associated with that link. As a result, links may be created and broken up at any time without the loss of moves or mutes. All current links in a mix are included in the information which is kept to disk, and the links will be re-formed when loading the mix from disk.

Important When a link member is touched, the current fader balance between link members will freeze (touching one is the same as touching all). Underlying moves will be recorded over, with the possibility that the amount of Match offset will vary from member to member. Performing a Match on one member will force all members to Match.

LINK CHARACTERISTICS

1. Any number of links may be formed.
2. A link may have any number of members.
3. A fader may be a member of only one link.
4. Link moves and events are recorded to each link member.
5. A fader cannot be assigned to one link and its mute to another.
6. Changing modes on a link member changes modes for all.
7. When a mix is kept to disk, links are included in the mix information.
8. Links are always functional, regardless of fader modes, automation status, or presence of timecode.
9. Channel buttons are not included in links.
10. Solo does not respect link assignments. (Soloing a member will not solo the other members.)

Note A fader may be assigned to both a link and a group. Link moves have priority over group moves, but group mutes will take precedence over link mutes.

TO CREATE A LINK:

1. Press LINK on the Global Master to enable the link assign mode (LINK LED on).
2. Press the SELECT button on a fader that is to be a link member (the SELECT LED will flash).
3. Press the SELECT button on each fader that you wish to add (SELECT LED on) or remove (SELECT LED off) from this link.
4. Press the SELECT button on the fader whose SELECT LED is flashing (SELECT LED off).
5. Repeat for other links or press LINK on the Global Master to disable the link assign mode (LINK LED off).

Note If you wish to delete all links currently in RAM, refer to Chapter 9, "Gangs".

TO TEMPORARILY SEPARATE A FADER FROM A LINK:

1. Touch any fader in the link other than the one you want to separate.
2. Touch the fader that you want to separate while keeping your finger on the first fader.
3. Take your finger off the first fader (while keeping your finger on the other fader). The second fader will be removed from the link temporarily, but will rejoin the link as soon as you release it.

ADJUSTING LINK FADER BALANCE

To adjust the relative balance of a fader in a link, separate it from the link and move it to the desired position.

TO TEMPORARILY SEPARATE A MUTE FROM A LINK:

1. Press any mute in the link other than the one you want to separate.
2. Press the mute that you want to separate while keeping your finger on the first mute.
3. Press the mute RECORD button of the first mute before releasing its mute button. This will prevent a toggle of the mute upon releasing the first mute button.
4. Toggle the separated mute as you like.

LINK INTERROGATION

Link interrogation may be performed by using the SELECT LED or by touching the faders.

INTERROGATION BY USING SELECT:

1. Turn off all assign mode buttons (GROUP, LINK, RSI, OTHER) on the Global Master.
2. Press the SELECT button on the fader of interest (SELECT LED will flash). The SELECT LEDs of all link members will flash.

INTERROGATION BY TOUCH:

1. Turn off all assign mode buttons (GROUP, LINK, RSI, OTHER) on the Global Master.
2. Touch the fader of the fader of interest (SELECT LED will flash). The SELECT LEDs of all link members will flash.

RSI (READY RECORD, SAFE, ISOLATE)

Faders and mutes can be set to Ready Record, Safe, or Isolate. If set to Ready, the playback and recording of moves and/or events is allowed. If set to Safe, the playback of previously made moves and/or events is allowed, but new moves or events can not be recorded. If set to Isolate, automation is disconnected, prohibiting the playback or recording of moves and/or events. RSI for faders and mutes may be set on individual faders or globally, by using the SELECT and RECORD buttons. The RECORD LEDs are used to indicate the current RSI setting of a fader or mute.

<u>RSI Setting</u>	<u>RECORD LED</u>
READY	flashing
SAFE	on solid
ISOLATE	off

Note These settings are shown only if RSI is on and the fader's SELECT button is pressed.

LOCAL FADER RSI SELECTION:

1. Press the RSI button on the Global Master to enable RSI assign (LED on).
2. Press and hold the SELECT button on the desired fader.
3. Press the fader RECORD button to select the desired setting.
4. Press RSI on the Global Master to disable RSI assign.

LOCAL MUTE RSI SELECTION:

1. Press the RSI button on the Global Master to enable RSI.
2. Press and hold the SELECT button on the desired fader.
3. Press the mute RECORD button to select the desired setting.
4. Press RSI on the Global Master to disable RSI.

GLOBAL FADER RSI SELECTION:

1. Press the RSI button on the Global Master to enable RSI.
2. Press and hold the SELECT button on the Global Master.
3. Press the fader RECORD button on the Global Master to select the desired setting.
4. Press RSI on the Global Master to disable RSI.

GLOBAL MUTE RSI SELECTION:

1. Press the RSI button on the Global Master to enable RSI.
2. Press and hold the SELECT button on the Global Master.
3. Press the mute RECORD button on the Global Master to select the desired setting.
4. Press RSI on the Global Master to disable RSI.

Note You may de-select any faders whose RSI setting you don't want changed by pressing their individual SELECT buttons (SELECT LED off) while pressing the SELECT button on the Global Master.

RSI INTERROGATION

If RSI is on, then the RSI setting of a fader or mute may be determined by pressing the SELECT button on the desired fader(s) and looking at the RECORD LEDs. RSI may be viewed globally or on individual faders.

TO VIEW RSI SETTINGS BY FADER:

1. Press RSI on the Global Master (LED on).
2. Press and hold the SELECT button on the desired fader to see the RSI status of that fader and mute.

TO VIEW RSI SETTINGS GLOBALLY:

1. Press RSI on the Global Master (LED on).
2. Press and hold the SELECT button on the Global Master to see the status of faders and mutes on all faders.

OTHER

The OTHER button on the Global Master allows you to access the Trim Faders dialog box, the Graph window, and the Set Solo Banks, Set Master Touch and Relay Control features. Graph is discussed in this section, but since Trim may be accessed via a menu as well as by OTHER, it is covered in Chapter 5, "Trim Faders".

GRAPH

This feature allows you to see moves made by a fader in any selected Mix/Pass. There are two ways fader moves may be displayed: The first shows one minute of moves (30 seconds on either side of the current timecode location). For example, if the timecode was stopped at 01:25:00, then moves from 01:24:30 to 01:25:30 would be drawn. The second mode displays ALL moves for the entire Mix/Pass.

Graphs are displayed in 6 colors to help distinguish them. Timecodes are the same color as their graph and displayed in 8 digit format without colons. Additionally, timecodes are displayed without Local Zero offset applied and therefore the timecode displayed for a graph will be exactly the same whether or not Local Zero is on. Remember that windows of this type may be moved and/or resized.

TO GRAPH FADER MOVES:

1. Make sure that the OTHER button on the Global Master is off.
2. Press the Global Master SHIFT+OTHER button, or click directly on *Other Key* box on the main screen, so that the box displays *Graph* (not *Trim*).
3. Press the OTHER button on the Global Master and the Graph window will be opened.
4. Press the SELECT button on the fader(s) that you wish to graph. (This displays one minute of moves.) To display all moves over the entire Mix, hold SHIFT on the Global Master and press SELECT on the desired fader(s).
5. Press the Global Master SHIFT+OTHER to clear the Graph window.
6. Press the OTHER button to close the Graph window.

SET SOLO BANKS

The Set Solo Banks feature allows you to change which faders are controlled by the Global and Multi-Man Solo systems. You may wish to set a default Global Solo set and default Multi-Man Solo sets as well in the System Initialization File (see Technical manual). However, you may wish to change this during a session and this OTHER mode allows you to do that.

If you are in Solo Global mode, the Select LEDs on each channel tell if that particular channel is part of the Global Solo system. In other words, if you press a member or members of the Global set, they will be unmuted while all other members will be muted. In this mode you can use the Select buttons to select/deselect faders.

TO SELECT WHICH FADERS ARE PART OF THE GLOBAL SOLO SYSTEM:

Either:

- 1) Change other mode to Set Solo Banks by pressing Shift+Other on the Global Master Module.
- 2) Select Other Mode by pressing the Other key.
- 3) Switch to Global Solo mode. or Use 'Select Faders for Global Solo' option in Gangs Menu.

Then:

- 1) Use Select buttons to (de)select faders to be part of Global Solo.
- 2) Press Other Key when finished.

If you are in Solo Multi-Man mode, you can use the Select buttons to form groups of faders that will work together in a solo. Selection of sets is exactly the same as setting link structures. For example, pressing the Select button on fader 1, then 2, then 3, selects a Multi-Man solo bank that includes faders 1, 2, and 3. Pressing fader 1, or turning off the OTHER mode, closes the operation. Now, if we press the solo button on fader 2, fader 2 will be unmuted and faders 1 and 3 become muted.

TO SELECT WHICH FADERS ARE PART OF THE MULTI-MAN SOLO SYSTEM:

Either:

- 1) Change other mode to Set Solo by pressing Shift+Other on the console.
- 2) Select Other Mode by pressing the Other key.
- 3) Switch to Multi-Man Solo mode (see above). or Use 'Select Faders for Multi-Man Solo' option in Gangs Menu.

Then:

- 1) Use Select buttons to select/deselect faders to be part of Multi-Man Solo in the same way you would define links (see section on defining links earlier in this chapter). Just as with links you may set up as many groups of solo-faders as you wish.
- 2) Press Other Key when finished.

If you are in Solo Off mode, the OTHER mode Set Solo Banks has no function.

SET MASTER TOUCH

The Set Master Touch feature allows you to change which faders and mutes are part of the Master Touch system. You may wish to set default members of the Master Touch system in the System Initialization File (see Technical manual). However, you may wish to change this during a session and this OTHER mode allows you to do that. If you enter this Set Master Touch mode, the mute Record LEDs indicate which mutes are in the Master Touch system and the fader Record LEDs indicate which faders are in the Master Touch system. The Select LED will be lit on a channel if either the mute or fader is part of the Master Touch system. You can use the mute and fader Record buttons respectively to select/deselect mutes and faders from the Master Touch set. See "Set Master Touch" in Chapter 9 for more information about Master Touch.

RELAY CONTROL

Some systems may have external Relay Control panels while others will not. If you do not have external control panels or if you wish to control relays from the fader buttons, you should use the Relay Control OTHER mode. In this mode, faders which have been associated with Relays (either through the Relay Setup Window under the Lists Menu or through the System Initialization File) will be controlled/examined via the associated channels' Select

LED and button. The button and LED work exactly the same as the external Relay buttons. For more information on the Relay System, see "Relay System" in Chapter 8.

FADER, MUTE, AND CHANNEL BUTTON RECORD MODES

This section explains the Record modes for faders, mutes, and channel events.

Important Recording of fader moves, and mute and channel events only occurs when:

1. Good timecode is being received (SHIFT LED on solid).
2. Run is selected (RUN LED is flashing).
3. Appropriate RECORD LED is flashing.

FADER RECORD MODES

When the RSI setting for a fader is set to Ready, various record modes become available. These modes may be selected at any time, at each individual fader or globally at the Global Master Module.

TOUCH RECORD

In this mode the fader starts by playing back the moves of the Play Pass. When you touch the fader, all moves that you make will be recorded. Upon release, the fader will resume playing back the moves of the Play Pass, along with any offset in level incurred. The Match LEDs will indicate if an offset is present.

Note If timecode is interrupted (stop tape, etc.) or RUN is turned off with an offset in effect, the offset will be carried out to the end of the mix. A Match must be performed if this is not desired. (Refer to "Match" in this section.)

TO SET A FADER TO TOUCH RECORD:

1. The selected fader's RSI must be set to Ready.
2. Press the fader RECORD button so that the fader Record LED and AUTO MATCH LED are both off.

TO GLOBALLY SET FADERS TO TOUCH RECORD:

1. The selected faders' RSI must be set to Ready.
2. Press the Global fader RECORD button so that the Global fader RECORD LED and AUTO MATCH LED are both off.

Note A fader's RECORD LED will flash slowly when recording in Touch Record. When in Play, the LED will be off.

LOCK RECORD

In this mode, the fader starts by playing back the moves of the Play Pass. When you touch the fader, all moves that you make will be recorded. Upon release, the fader will continue in record as if being touched, staying in the position where you released it. (If the fader is in a group or a link, it will still follow all group or link moves while recording in Lock Record.) Recording ends at that point in the mix when one of the following occurs:

1. A Match is performed.
2. The fader is taken out of Ready.
3. Run is turned off.
4. Timecode is stopped (stop tape, etc.).

The MATCH LEDs will indicate if an offset is present.

Note If timecode is interrupted (stop tape, etc.) or RUN is turned off with an offset in effect, the offset will be carried out to the end of the mix. A Match must be performed if this is not desired. (Refer to "Match" in this section.)

TO SET A FADER TO LOCK RECORD:

1. The selected fader's RSI must be set to Ready.
2. Press the fader RECORD button so that the fader RECORD LED is on and the AUTO MATCH LED is off.

TO GLOBALLY SET FADERS TO LOCK RECORD:

1. The selected faders' RSI must be set to Ready.
2. Press the Global fader RECORD button so that the Global fader RECORD LED is on and the AUTO MATCH LED is off.

Note A fader's RECORD LED will flash quickly when recording in Lock Record and will be on solid in Play.

AUTO MATCH

In this mode, the fader starts by playing back the moves of the Play Pass. When you touch the fader, all moves that you make will be recorded. Upon release, the fader will automatically perform a Match, gliding back to the Auto Match position. When the Glide ends, play is resumed. The Auto Match Glide rate may be changed from the Glide Times dialog box. (Refer to Chapter 6, "Glide Times".)

Notes If timecode is interrupted (stop tape, etc.) or RUN is turned off with an offset in effect, the offset will be carried out to the end of the mix. A Match must be performed if this is not desired. (Refer to "Match" in this section.)

As the fader glides during an Auto Match, it will increasingly follow the dynamics of the Play Pass moves.

TO SET A FADER TO AUTO MATCH:

1. The selected fader's RSI must be set to Ready.
2. Simultaneously press the fader RECORD and MATCH buttons. (The AUTO/MATCH LED will come on solid.)

TO GLOBALLY SET FADERS TO AUTO MATCH:

1. The selected faders' RSI must be set to Ready.
2. Simultaneously press the fader RECORD and MATCH

buttons on the Global Master . (The AUTO/MATCH LED will come on solid.)

Notes The fader RECORD LED will flash when recording in Auto Match. (Recording occurs while the fader is being touched and during the Glide.) The AUTO/MATCH LED will flash while the fader is Gliding. When playing, the RECORD LED will be off and the AUTO/MATCH LED will be on solid.

In the Auto Match mode, the MATCH LEDs point toward the Auto Match position while recording a move. When the fader is playing moves, the MATCH LEDs point toward the Play Pass position (if there is an offset). Pressing the MATCH button will perform a Match (not Auto Match) eliminating the offset from the Play Pass position.

MATCH

Whenever you want the fader to Glide from its current position to the Play Pass position, press the MATCH button and the fader will move to the Play Pass position. Once there, recording ends and playback of old moves begins. The Match Glide rate may be changed from the Glide Times dialog box. (Refer to Chapter 6, "Glide Times".)

Notes As the fader glides during a Match, it will increasingly follow the dynamics of the Play Pass moves.

Match does not affect faders in Isolate.

TO PERFORM A LOCAL MATCH:

Press the MATCH button on the fader at the point in the mix that you wish the fader to Glide to the Play Pass position.

TO PERFORM A GLOBAL MATCH:

Press the MATCH button on the Global Master at the point in the mix that you wish all faders to Glide to their respective Play Pass positions.

Note The fader RECORD LED will flash when recording in the Match mode. The AUTO/MATCH LED will flash while the fader is Gliding.

MUTE RECORD MODES

When RSI for a mute is set to Ready, two record modes become available. These modes may be selected at any time at each individual mute, or globally at the Global Master Module.

TOUCH RECORD

In this mode, the mute starts by playing back the mutes of the Play Pass. Upon pressing down on the mute button, record is activated. During the time that you hold the button down, all underlying Play Pass mutes will be ignored. Upon releasing the mute button, the mute will toggle and recording ends. The mute will resume playback of the Play Pass at the next event which will cause the mute to toggle to the opposite state.

Important If two sequential "on" mutes exist on the same channel, the latter mute will remain in the Mute List as long as tape (timecode) does not play past that mute. For example, a mute "on" has been recorded at 01:05:45:03. On a subsequent pass, a mute "on" is recorded two minutes prior at 01:03:44:27 and then tape (timecode) is stopped before the mute at 01:05:45:03. If you look at the Mute List, both mutes are included in the list and do, in fact, exist. On the other hand, if tape (timecode) is played past the mute at 01:05:45:03 and no other mutes exist between these two points, the mute at 01:05:45:03 will be deemed redundant and removed, automatically creating a new Mix/Pass.

TO SET A MUTE TO TOUCH RECORD:

1. The selected mute's RSI must be set to Ready.
2. Press the mute RECORD button so that the mute RECORD LED is off.

TO GLOBALLY SET MUTES TO TOUCH RECORD:

1. The selected mutes' RSI must be set to Ready.
2. Press the mute RECORD button on the Global Master so that the mute RECORD LED is off.

Note A mute's RECORD LED will flash slowly when recording in Touch Record and will be off while playing.

TO ERASE MUTE EVENTS:

1. The selected mute's RSI must be set to Ready.
2. Select the Touch Record mode.
3. Press down on the mute button (to activate record) just ahead of the mute event to be erased.
4. Continue to hold the mute button down until you have passed the unwanted mute event(s).
5. Press the mute RECORD button before releasing the mute button. This will cause the mute not to toggle upon release of the mute button.

LOCK RECORD

In this mode the mute starts by playing the mutes of the Play Pass. Upon pressing down on the mute button, record is activated and locked on. Upon releasing the mute button, the mute toggles and recording continues. As long as record is activated, all underlying Play Pass mute events will be ignored. Recording ends when one of the following occurs:

1. The mute is taken out of Ready.
2. Run is turned off.
3. Timecode is stopped (Stop tape, etc.).

Important If two sequential "on" mutes exist on the same channel, the latter mute will remain in the Mute List as long as tape (timecode) does not play past that mute. For example, a mute "on" has been recorded at 01:05:45:03. On a subsequent pass, a mute "on" is recorded two minutes prior at 01:03:44:27 and then tape (timecode) is stopped before the mute at 01:05:45:03. If you look at the Mute List, both

mutes are included in the list and do, in fact, exist. On the other hand, if tape (timecode) is played past the mute at 01:05:45:03 and no other mutes exist between these two points, the mute at 01:05:45:03 will be deemed redundant and removed, automatically creating a new Mix/Pass.

TO SET A MUTE IN LOCK RECORD:

1. The selected mute's RSI must be set to Ready.
2. Press the mute RECORD button so that the mute RECORD LED is on solid.

TO GLOBALLY SET MUTES IN LOCK RECORD:

1. The selected mutes' RSI must be set to Ready.
2. Press the mute RECORD button on the Global Master so that the mute RECORD LED is on solid.

Note A mute's RECORD LED will flash quickly when recording in Lock Record and will be on solid while playing.

CHANNEL BUTTON RECORD MODES

This section explains Touch Record and Isolate for channel buttons.

TOUCH RECORD

If set to Touch Record, the channel buttons start by playing back the events of the Play Pass. Upon pressing down on a channel button, record is activated for that button. During the time that you hold the button down (activating record) all underlying Play Pass events for that button will be ignored. Upon release, it will toggle and recording ends. The channel button will resume playback of the Play Pass.

ISOLATE

Channel buttons are unaffected by fader and mute RSI settings, but they may be placed in Isolate by disabling the desired channel button in the Automate Channel Buttons dialog box. (Refer to Chapter 6, "Automate Channel Buttons", in the Options menu.)

SOLO

The Flying Faders solo system works independently of a console's solo and is accessed by the solo buttons above the select buttons on each fader. The main features of the solo system are:

- 1) Multi-man solo operation allows the console to be divided to allow individual solo systems for several users at once.
- 2) Solo may be disabled on particular channels allowing effect returns and masters, for example, to be excluded from the solo system.
- 3) Soling a channel does not disturb previously recorded mutes.
- 4) New mute events can be recorded on channels that are begin solo'ed.
- 5) Momentary or latching button operation.
- 6) Solo'ed group masters solo their slaves as well.

TO SELECT GLOBAL SOLO/MULTI-MAN SOLO/DISABLED SOLO:

Press the Global Master SHIFT+SOLO or click on the Solo Box on the main screen to disable solo and to switch between multi-man and global operation.

TO SOLO A CHANNEL:

- 1) Enable solo to either Global or Multi-Man operation.
- 2) Press SOLO on the channel or channels that you wish to solo.

The solo'ed faders will be unmuted regardless of their mute state and the other faders in the Solo section will be muted. With automation on and solo engaged, mutes will not play on faders within the solo group, although you can still record mutes normally.

MOMENTARY OR LATCHING OPERATION

The solo buttons may be set to momentary or latching operation. The SOLO button on the Global Master is used to toggle between these two modes. In latched mode, pressing the solo button will solo a fader until solo is pressed again. In momentary mode, the fader stays solo'ed only while the solo button is pressed. In addition to changing between momentary and latched mode, the master Solo button will unsolo any latch-solo'ed faders.

Additional Notes On Solo

Solo does not recognize Link structures, but it does recognize groups. Pressing solo on a group master will act exactly as if the solo button was pressed on all the slaves as well.